

# DE-1T

*Trunk Dendrometer*



**Implexx Sense**  
Digital Environmental Sensing

[www.implexx.io](http://www.implexx.io)  
[info@implexx.io](mailto:info@implexx.io)

## **Introduction**

The DE-1T Dendrometer is a highly precise incremental LVDT-based sensor for monitoring micro-variations of trunk radius in micron range.

The sensor includes a linear displacement transducer (LVDT) mounted on a special rod with threaded end. When the rod is anchored inside the trunk, the LVDT rod follows movement of the trunk surface. The output signal follows the variation of distance between trunk surface and the anchored end of the rod.

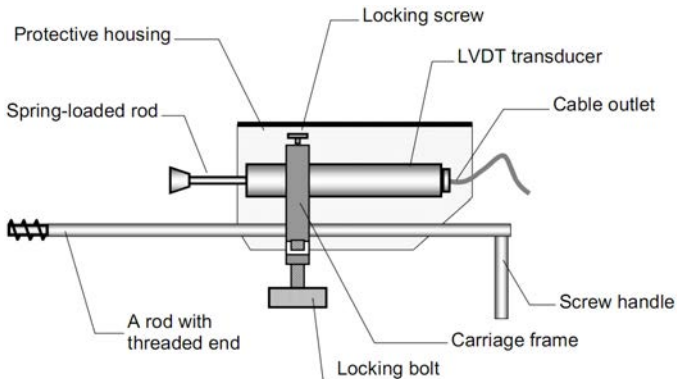

The probe is connected by a standard 1-meter cable to the waterproof box with the signal conditioner inside. A signal conditioner provides excitation of the LVDT and production of standard linear output signal. The output cable length should be specified in the order if required.

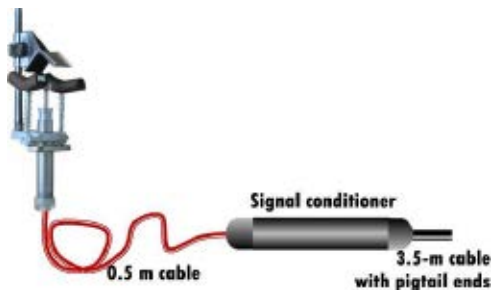

## **Connection**

The connection diagram is shown below. The shield shall be grounded at the data loggers side or connected to the ‘minus’ contact of the power source.

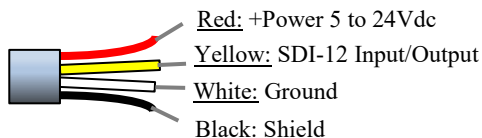

## **Data logging**

**SDI-12** : single output with the M! or C! command in accordance with SDI-12 Standard (version 1.3).

## ***Installation***

- In trees with rough bark over the cambium, rasp it away and pare down carefully an area of about 6 L × 5 W cm<sup>2</sup>. In caulis and species with smooth bark, no preparation may be needed.
- Drill the hole with the 3.3 – 3.5 mm bits. It is recommended to drill slowly using a wood drill set to a low torque to prevent excessive tearing of wood fibers along the length of hole. The depth of hole must be 3 cm min. and 9 cm max.
- Free the locking bolt and remove the rod from the carriage frame.
- Carefully screw the rod into the tree. If there is difficulty in insertion, clear the hole carefully with the drill bit.
- Once the rod is implanted, set the sensor on the rod and adjust its position until the butt of spring-loaded rod touches the trunk.
- Readjust the sensor when its readings become close to 0 or 10 mm.

# **SDI-12 Communication**

## *Default Address*

0

## *Identification I! Command*

SDI-12 command: 0I!

Returns: 013BIOINST DE-1T 3.026

Sensor address: 0

SDI-12 version: 1.3

Vendor: BIOINST

Model: DE-1T

Version Number: 3

Sensor Serial Number: 026

## *Measurement M! Command*

SDI-12 command: 0M!

Returns: 00011

Return 1 measurement after 1 second settling period

## *Measurement Range, Resolution and Units*

DE-1T: 0.000 - 10000 micrometres (um)

## ***Specifications***

Measurement linear range (LVDT stroke)	0 to 10 mm
Trunk diameter range	Above 6 cm
Output DE-1T	SDI-12
Resolution	0.005 mm (w/filter)
Operating temperature	0 to 50 °C
Temperature effect	< 0.02% total stroke / °C
Supply voltage	5 to 24 VDC
Power DE-1T	1.5 W max
Protection index	IP 64
Overall dimensions, mm	90 W × 60 H × 23 D
Carrying rod, mm	160 L × 4 Ø
Threaded end, mm	10 L × 5 Ø
Cable length between probe and signal conditioner	1 m

# ***Customer Support***

Implexx Sense

PO BOX 285  
Moorabbin, VIC, 3189,  
Australia

Email: [info@implexx.io](mailto:info@implexx.io)

Web: [www.implexx.io](http://www.implexx.io)



# **Implexx Sense**

**Digital Environmental Sensing**